



CRYSTAL TIPS[®]

ICE PRODUCTS

AUTOMATIC ICE SYSTEM

Use and Care Guide

Parts and features

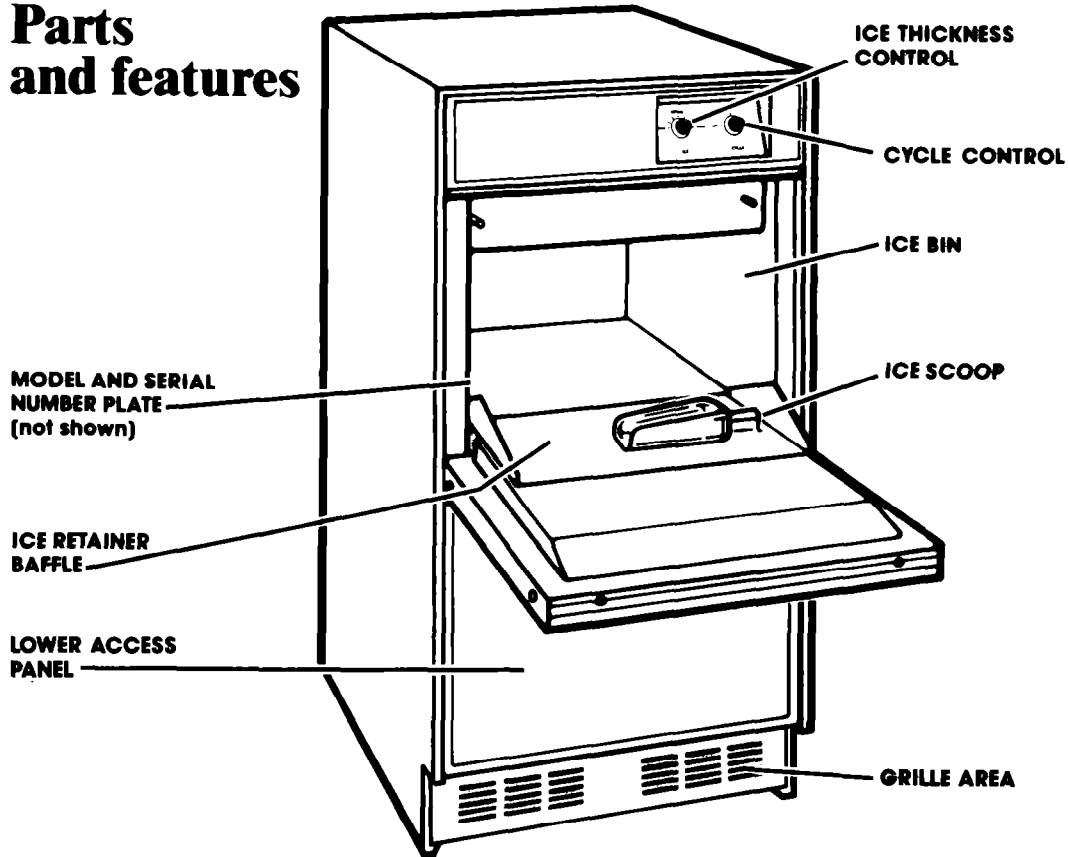

Copy your Model and Serial Numbers here...

When you need service, or call with a question, have this information ready:

- 1. Complete** Model and Serial Numbers (from the plate located as shown).
- Purchase date from sales slip.

Copy this information in these spaces. Keep this book, your warranty and sales slip together in a handy place.

Model Number _____

Serial Number _____

Purchase Date _____

Service Company and Telephone Number _____

Contents

	Page		Page
BEFORE YOU PLUG IT IN	2	Cleaning Exterior Surfaces	5
USING YOUR ICE MAKER	2	Cleaning the Condenser	5
How the Ice Maker Works	2	Cleaning the Ice Maker System	6
Setting the Controls	3	Cleaning the Interior Components	7
Changing the Bin Door Panel	3	Filtering and Treating Water	8
Changing the Lower Access Panel	4	VACATION AND MOVING CARE	8
CLEANING AND CARING FOR YOUR		IF YOU NEED SERVICE OR ASSISTANCE ..	12
ICE MAKER	5	Before Calling for Service	12

Before you plug it in

IMPORTANT

Before using your ice maker, you are responsible for making sure that it...

- has been installed where it is protected from the elements.
- is located so that the front is not blocked to restrict incoming or discharge air flow.
- is properly leveled.
- is located in a well ventilated area with temperatures above 55°F (13°C) and below 110°F (43°C). Best results are obtained at temperatures between 70°F (21°C) and 90°F (32°C).
- is properly connected to a water supply and drain.
- is properly connected to electricity. A 115 Volt, 60 Hz., 15 amp fused electrical supply is required. **NOTE:** Time delay fuse or circuit breaker is recommended.
- is properly electrically grounded.
- is not operated by anyone unable to use it properly.
- is used only for the job it was designed to perform.
- is properly maintained.

Using your ice maker

How the ice maker works

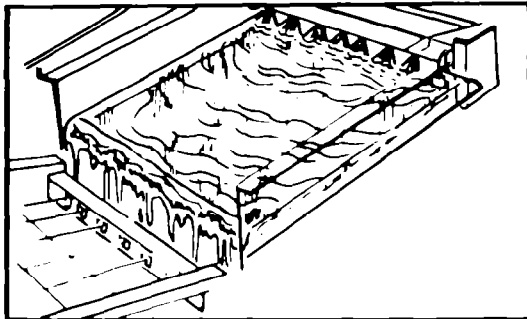

1. Water is constantly circulated over a freezing plate. As the water freezes into ice the minerals in the water are rejected. This produces a clear sheet of ice with a low mineral content.

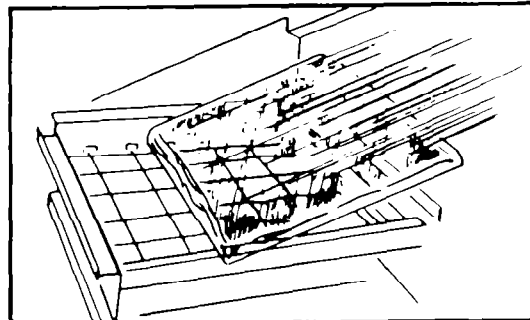

2. When the desired thickness is reached, the ice sheet is released and slides onto a cutter grid. The grid divides the sheet into individual cubes.

3. The water containing the rejected minerals is drained after each freezing cycle.
4. Fresh water enters the machine for the next ice making cycle.
5. Cubes fall into the storage bin. When the bin is full the ice maker shuts off automatically and restarts when more ice is needed.

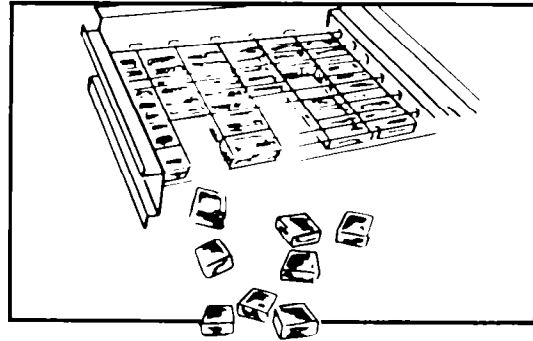

Setting the controls

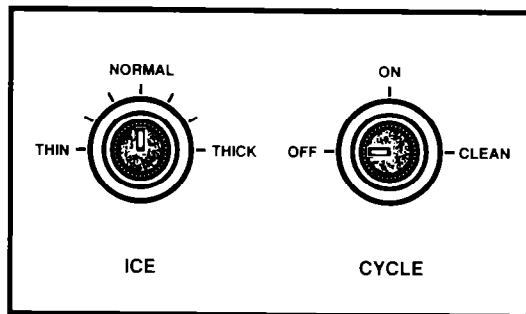

1. Select ice thickness. The ice maker has been pre-set to produce ice approximately $\frac{1}{2}$ " thick, while operating in a room ambient of 70°F (21°C).

Operation in different ambient temperatures may require readjusting the control toward "THICK" or "THIN."

Best operation will be obtained with ice $\frac{1}{2}$ " to $\frac{5}{8}$ " thick.

If operating in a warm room ambient (above 90°F [32°C]) **DO NOT** set control to maximum thickness or the unit may malfunction.

2. To start the normal ice making cycle, turn the Cycle Control Knob to "ON."

3. To stop ice maker operation, turn Cycle Control Knob to "OFF."

The "CLEAN" setting is used whenever solutions are circulated through the ice maker for cleaning. Only the water pump operates at this setting.

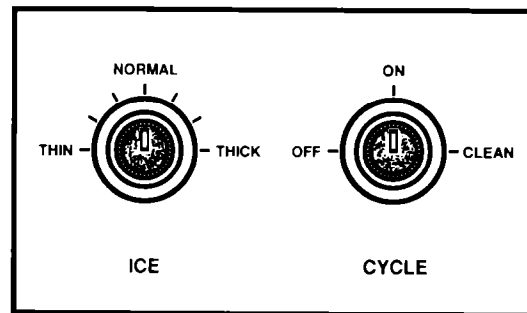

Changing the bin door panel

You can make a decorative wood front to match existing cabinets.

To change panel:

1. Open the storage bin door. Remove the two screws on the top of the door which hold the handle.
2. Loosen the screws in both of the side trim pieces.
3. Remove the handle.

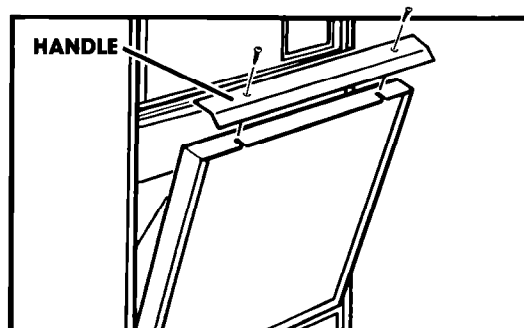

4. Carefully slide the panel out and break off the ribs on the door insulation to allow room for wood panel thickness.

5. Make the wood panel $\frac{1}{4}$ " (6 mm) thick and 17" x 13 $\frac{3}{8}$ " (433 mm x 335 mm).

6. Replace the handle and tighten the screws in both side trim pieces. Replace the handle screws.

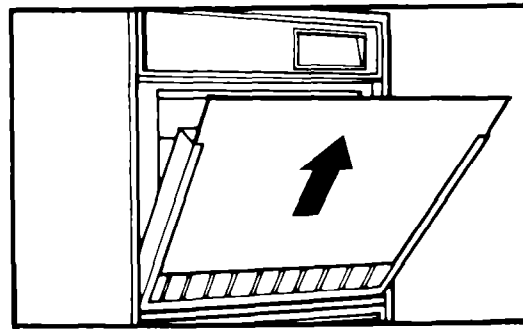

Changing the lower access panel

⚠ WARNING

Electrical Shock Hazard

Do not operate ice maker with lower access panel or control panel removed. Electrical shock or personal injury could result.

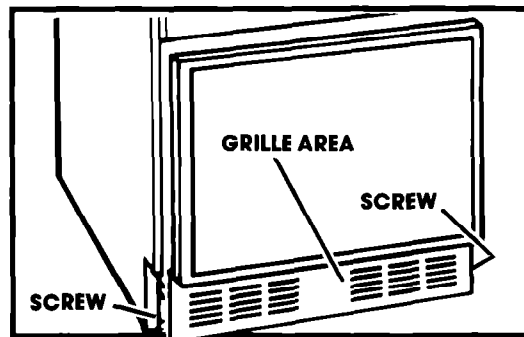

1. Remove the two screws in the bottom grille area.

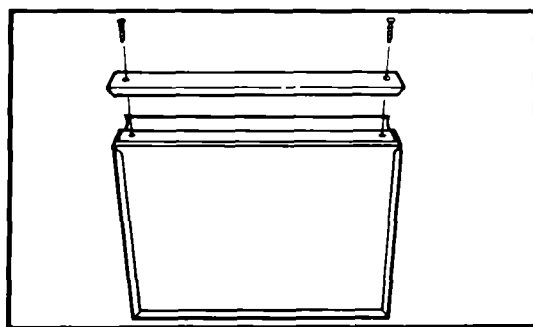

2. Remove the two screws from the top panel trim and remove the top trim.

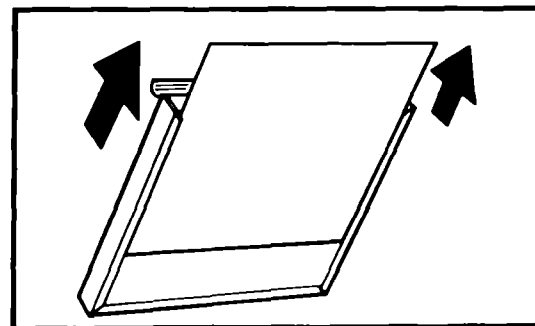

3. Carefully slide the panel out.

4. Make a decorative wood front to match existing cabinets. The panel should be $\frac{1}{4}$ " (6 mm) thick and 17" x 11 $\frac{5}{8}$ " (433 mm x 303 mm).

5. Replace the top trim and screws. Replace the lower grille area assembly and screws.

Cleaning and caring for your ice maker

Periodically inspect and clean the ice maker to keep it operating at peak efficiency and to prevent premature failure of system components.

Both the ice making system and the air cooled condenser need to be cleaned regularly.

The minerals rejected from the circulating water during the freezing cycle will eventually form a hard scaly deposit in the water system which prevents a rapid release of the ice from the freezing plate.

Clean the ice and water system periodically to remove mineral scale build-up. Frequency of cleaning depends on water hardness. With soft water, cleaning may not be required for several years. With hard water (15 to 20 grains/gal.), cleaning may be required as frequently as every six months.

A dirty or clogged condenser:

- prevents proper air flow.
- reduces ice making capacity.
- causes higher than recommended operating temperatures which may lead to component failure.

Cleaning exterior surfaces

Wash the exterior enamel surfaces and gaskets with warm water and mild soap or detergent. Rinse and dry. Regular use of a good household appliance cleaner and wax will help protect the finish.

Do not use harsh or abrasive cleaners on enamel surfaces as they may scratch the finish.

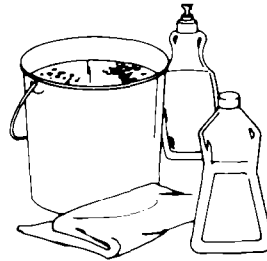

Cleaning the condenser

⚠ WARNING

Personal Injury and Product Damage Hazard

- Be sure the ice maker is **OFF** and disconnected from the main power supply. Condenser fan rotation, sharp condenser fins and hot tubing could cause personal injury.
- Condenser fins can bend easily. Use care when vacuuming the condenser to keep from bending fins. Product damage could result.

1. Disconnect electrical power supply to the machine and place the Cycle Control Knob in the "OFF" position.

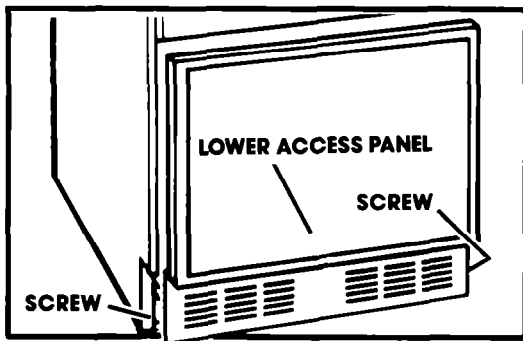

2. Remove the two screws from the bottom of the grilled front panel.
3. Pull forward and down to remove the panel.

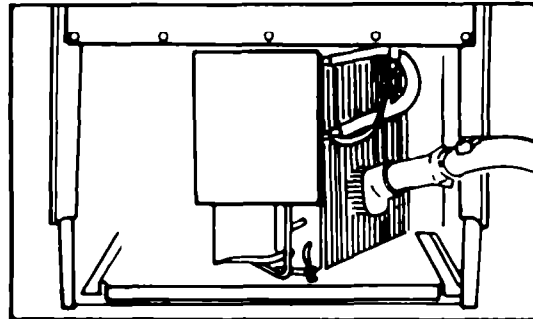

4. Remove dirt and lint from the condenser fins and the unit compartment with a brush attachment attached to a vacuum cleaner.
5. Replace the grilled front panel and screws.
6. Plug unit in and place the Cycle Control Knob in the "ON" position.

Cleaning the ice maker system

⚠ WARNING

Personal Injury Hazard

Most ice machine cleaners are citric or phosphoric acid which can cause irritation even after dilution. In case of contact with eyes, flush eyes thoroughly with fresh water and contact a physician immediately. In case of contact with skin, rinse well with water. If *swallowed*, give large amounts of water and contact a physician immediately. Do not induce vomiting. **KEEP OUT OF REACH OF CHILDREN.**

1. Place the Cycle Control Knob in the "OFF" position.

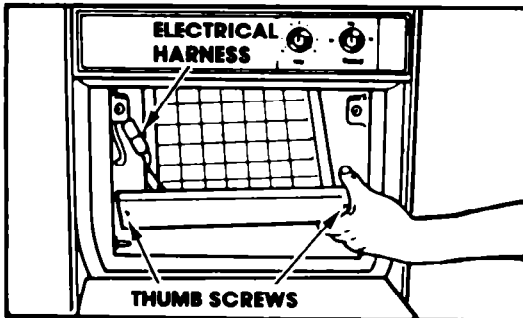

2. Remove the two thumb screws and slide the ice cutter grid forward, out of the two slots near the water pan.
3. Unplug the electrical harness.

⚠ CAUTION

Any ice on the grid should be melted under running warm water. Attempting to pick the ice slab off the grid may stretch and damage grid wires.

4. Remove all ice from the storage bin and the freezing plate.

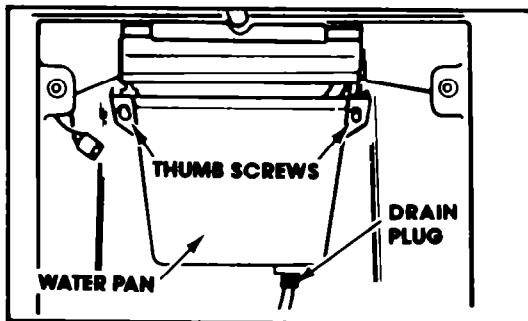

5. Drain the water pan by removing the drain plug and then replace the plug.

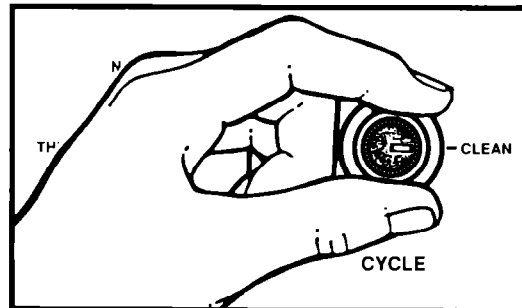

6. Pour ½ gallon (1.9 L) of hot tap water into the water pan and turn the Cycle Control Knob to "CLEAN." This warms up the system to make the cleaning solution more effective. Let circulate for five minutes. While tap water is circulating, prepare cleaning solution. Mix:

6 oz. (170 g) powdered citric,
or phosphoric acid into
½ gallon (1.9 L) hot water

(Citric and phosphoric acid crystals are available from many pharmacies or scientific supply houses.)

Commercial ice machine cleaners (liquid) are also available from your dealer or refrigeration parts supply stores. Mix according to instructions on label (total quantity ½ gallon [1.9 L]).

7. Turn Cycle Control Knob to "OFF" and drain the water pan. (See step 5.)
 8. Turn the Cycle Control Knob to "CLEAN" and slowly pour the hot cleaning solution into the water pan. (If solution foams while pouring, wait until foaming stops.) Then add the balance of the solution.
- Allow solution to circulate until the scale has dissolved (15 to 20 minutes). Severe scale build-up may require repeated cleaning with a fresh quantity of cleaning solution.
- To clean scale off the side flanges of the freezing plate, use rubber gloves and scrub with a plastic scrubbing pad or non-soap filled stainless steel pad dipped in cleaning solution.
9. Keep rubber gloves on to drain the cleaning solution. Turn the Cycle Control Knob to "OFF" and drain the water pan. (See step 5.)
 10. Replace the plug and add ½ gallon (1.9 L) of fresh water. Set Cycle Control Knob on "CLEAN," circulate five minutes and drain. Repeat rinsing process.

Cleaning the interior components

⚠ WARNING

Personal Injury Hazard

Do not operate the ice maker with the lower access panel, grille area or control panel removed. Personal injury could result.

1. Turn the Cycle Control Knob to "OFF" and disconnect the electrical power supply to the machine. Open the storage bin door and remove any ice that is in the bin.

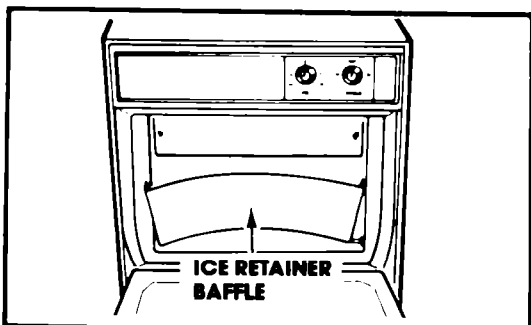

2. Remove ice retainer baffle by flexing it and then slide it off the studs.

3. Remove the ice cutter grid by unscrewing the two thumb screws, sliding the grid forward and unplugging the electrical wire harness.

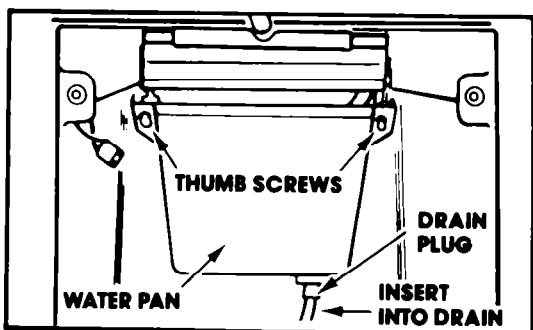

4. Remove the water pan by unscrewing the two thumb screws.

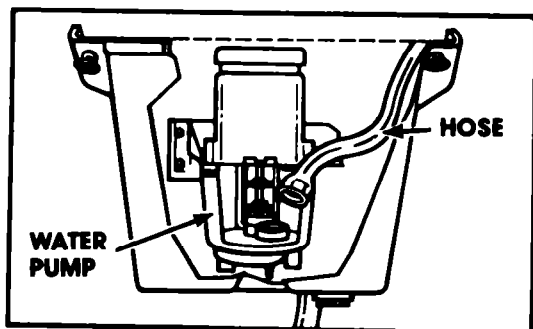

5. Remove the hose from the water pump.

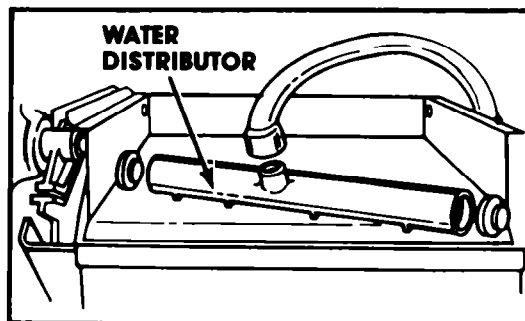

6. Remove the water distributor from the freezing plate. It is held in place by rubber end caps. Remove the inlet hose and clean all water distributor holes and the small orifice in the inlet side of the distributor. When replacing the distributor, make sure the end caps are located in the evaporator flange detents and that the water distributor holes face down.

7. Wash the **interior components** (ice retainer baffle, cutter grid, water pan, inlet hose and water distributor) and the storage bin, door gasket and ice scoop with mild soap or detergent and warm water. Rinse in clean water. These components should also be cleaned in a solution of ¼ oz. (8 ml) of chlorine bleach with 1 gallon (3.8 L) warm water.

DO NOT WASH PLASTIC PARTS IN DISHWASHER.

They cannot withstand temperatures above 145°F (63°C).

8. Replace the interior components: water distributor, inlet hose, water pan, cutter grid and ice retainer baffle.
9. Check the following:
 - Hose from water valve is in water pan.
 - Rubber drain plug is in water pan.
 - Water distributor is seated and holes are facing down.
 - Hose is reconnected to pump and water distributor.
 - Hose from water pan is inserted into storage bin drain opening.
10. Reconnect electrical harness, slide cutter grid into place and tighten the thumb screws.

Filtering and treating water

In most areas it will be beneficial to filter or treat the water being supplied to the ice machine. It can improve the reliability of the machine, reduce water system maintenance and produce the best quality of ice.

The installation of a polyphosphate feeder will generally reduce scale build-up and the ice machine will require less frequent cleaning.

Municipal water systems are generally treated with chlorine to maintain a safe potable water supply. Activated carbon filters will sufficiently remove the residual chlorine from the water to reduce surface staining of stainless steel materials in the ice machine.

For information on filtering and treating the water, see the dealer from whom you purchased your ice maker.

Vacation and moving care

To shut down the ice maker:

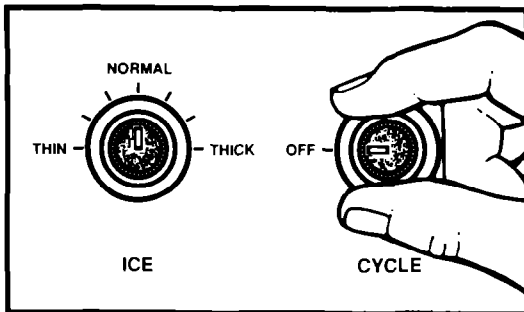

1. Turn the Cycle Control Knob to "OFF"
2. Remove all ice from storage bin.
3. Shut off the water supply.

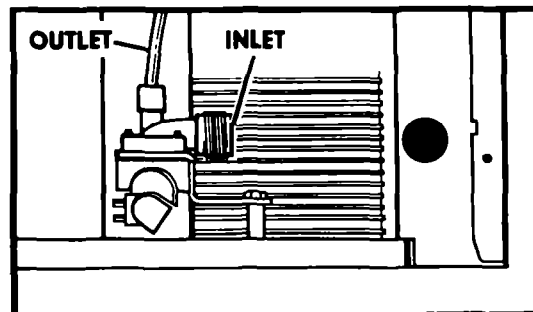

5. Disconnect the inlet and outlet lines to water valve. Allow these lines to drain and then reconnect to the valve.
6. Replace front grille and screws.

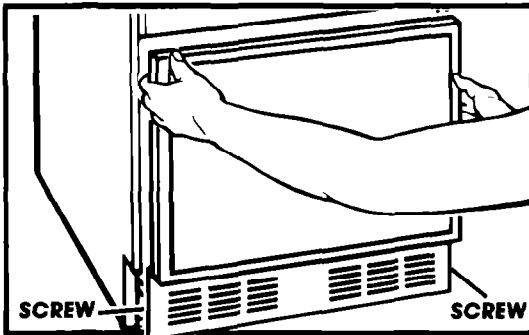

4. Remove two screws from base of grille area, then remove lower access panel.

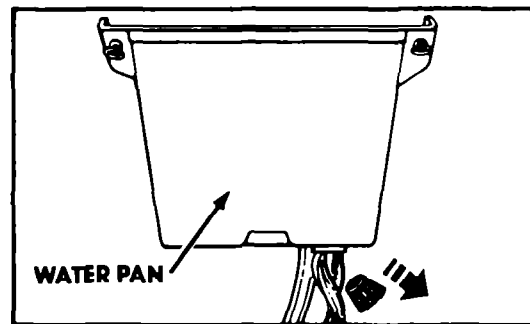

7. Remove water from drain lines and drain water pan.
8. Before using again, clean the ice maker, interior components and storage bin.

NOTE: All components of the ice maker are permanently lubricated at the factory. They should not require any additional oiling throughout the normal life of the machine.

Notes

Notes

Notes

If you need service or assistance, we suggest you follow these steps:

Before calling for service...

Performance problems often result from little things you can find and fix yourself without tools of any kind.

Unit does not run:

- Cycle Control Knob must be in the "ON" position.
- Check to see that power cord is plugged in.
- Check for blown fuse or tripped circuit breaker in electrical supply to machine.
- Room temperature must be above 55°F (13°C). Otherwise, bin thermostat may sense cold room temperature and shut off even though bin is not full of ice. Also, unit may not restart once it does shut off.

Unit runs but produces no ice:

- Cycle Control Knob must be in the "ON" position.
- Check water supply to make sure it is open.
- If ice machine is operated at an elevation of 2,000 feet or more above sea level, both the bin thermostat and ice thickness thermostat need to be recalibrated. See Installation Instructions.

Unit runs but produces very little ice:

- Room temperature may be extremely high, over 90°F (32°C). In this case, it is normal for ice production to be low.
- Dirt or lint may be blocking the air flow through the finned condenser. Condenser needs to be cleaned.
- Check to see if the unit has a scale build-up in water and freezing system. Clean, if necessary.

Grid is not cutting ice sheets:

- Check the grid harness plug to make sure the connection is secure.

Taste in ice cubes:

- There may be an unusually high mineral content in water supply. Water may need to be filtered or treated.
- Do not store any foods in the ice bin.
- Packaging material not all removed.